

Appendix C

TYPICAL HIGHWAY CROSS SECTIONS

A

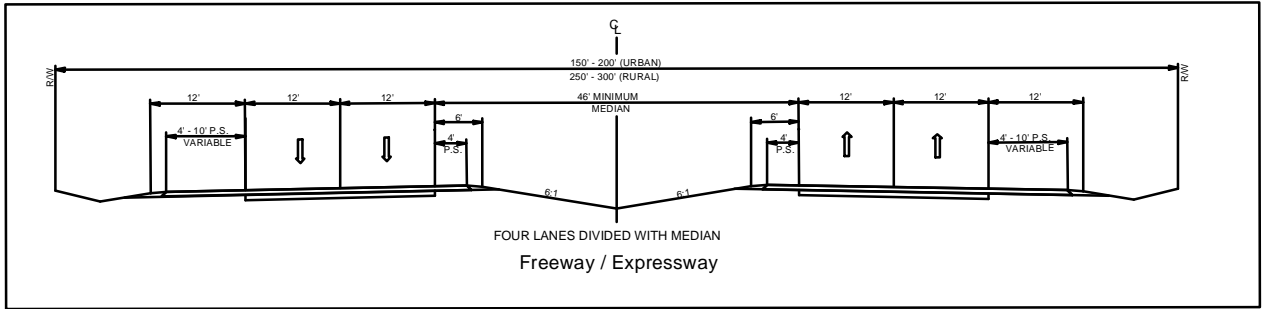

B

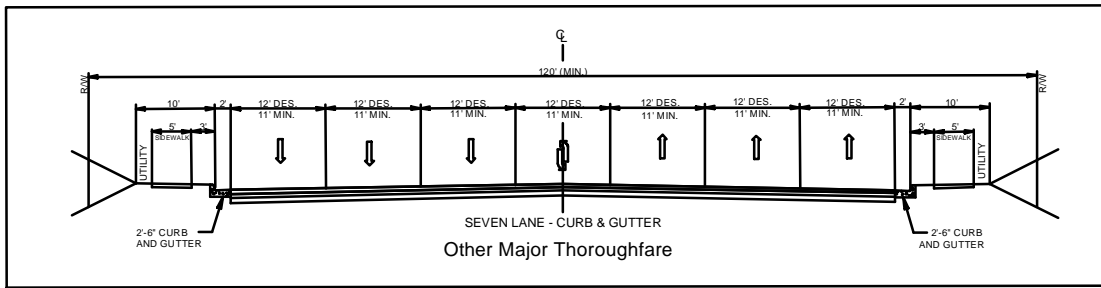

C

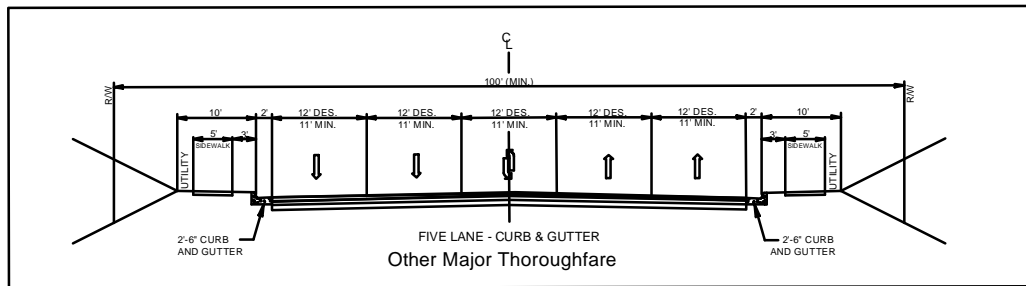

D

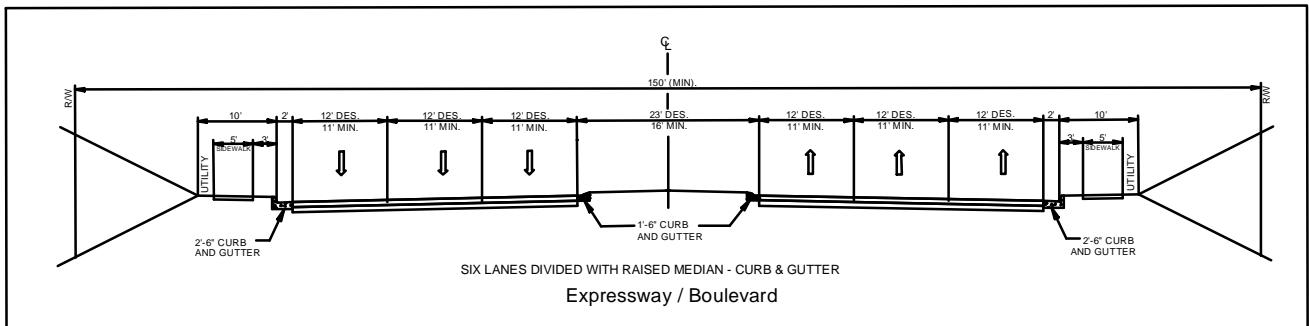

TYPICAL HIGHWAY CROSS SECTIONS

E

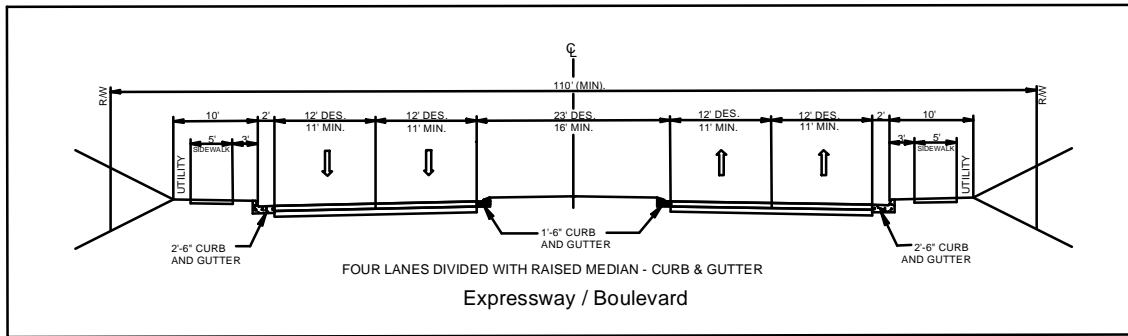

F

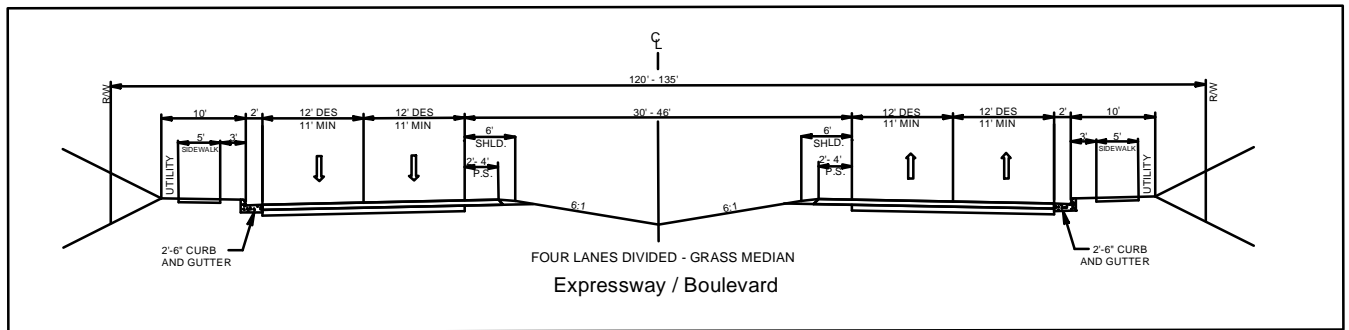

G

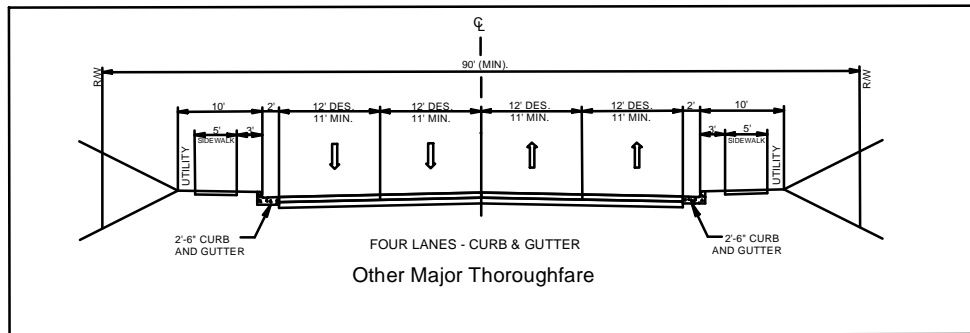

H

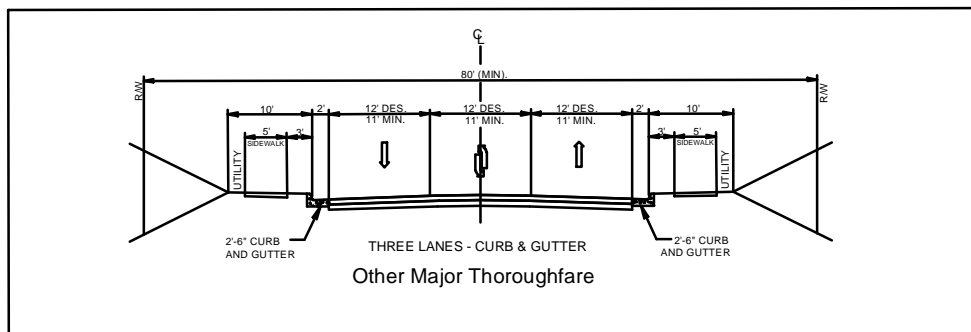

TYPICAL HIGHWAY CROSS SECTIONS

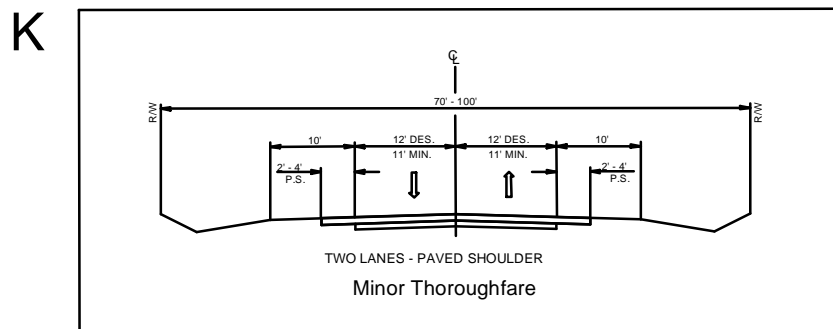
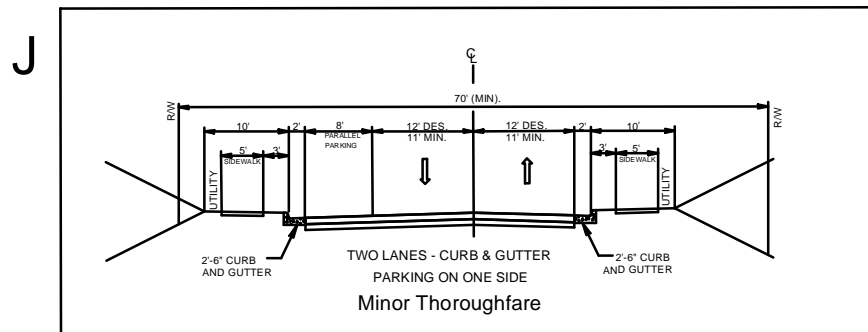
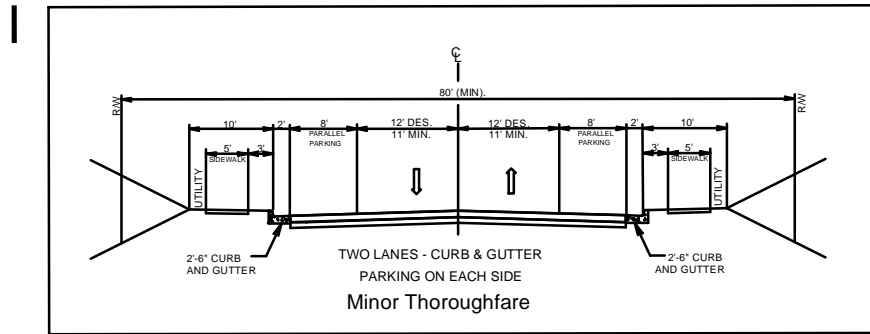

TYPICAL HIGHWAY CROSS SECTIONS

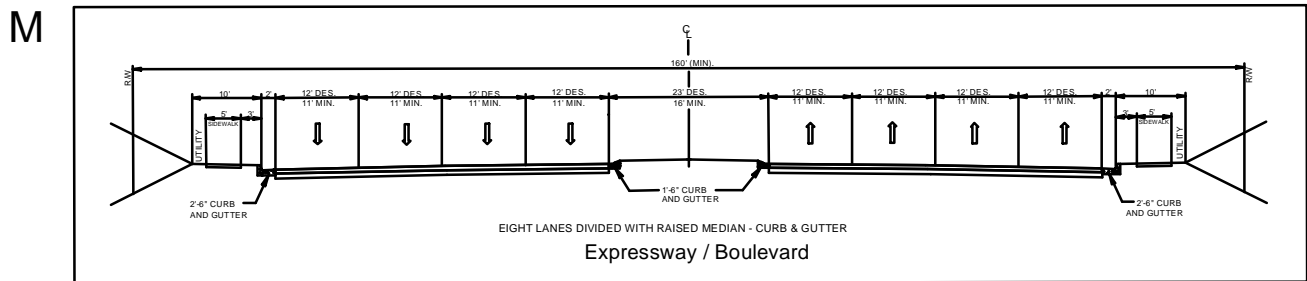
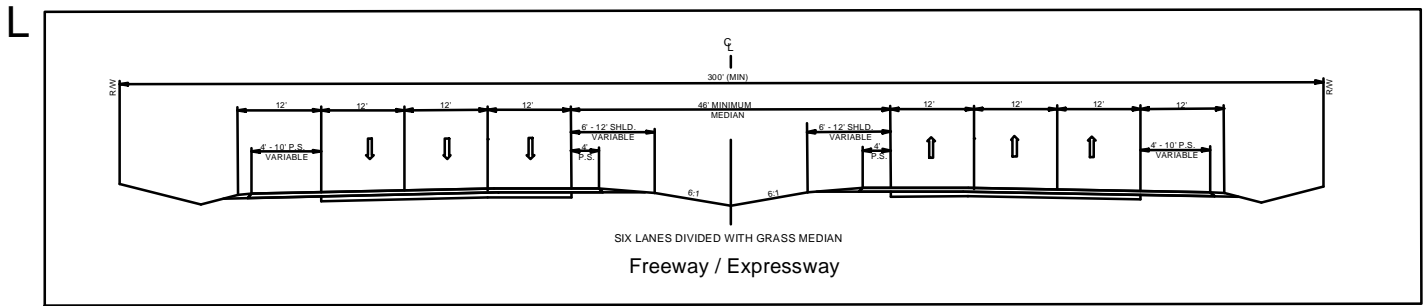

Typical Bicycle Cross Sections

WIDE CURB LANES

B-1 4-LANE MEDIAN DIVIDED TYPICAL SECTION With Wide Outside Lanes

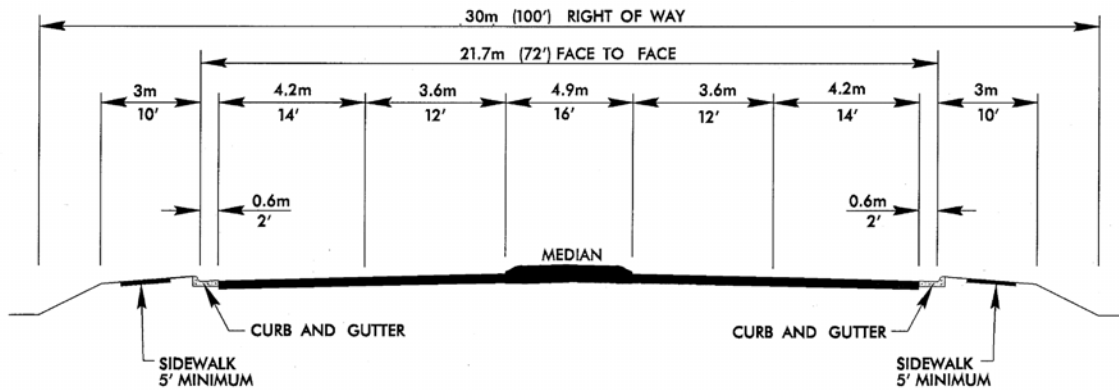

B-2 5-LANE TYPICAL SECTION With Wide Outside Lanes

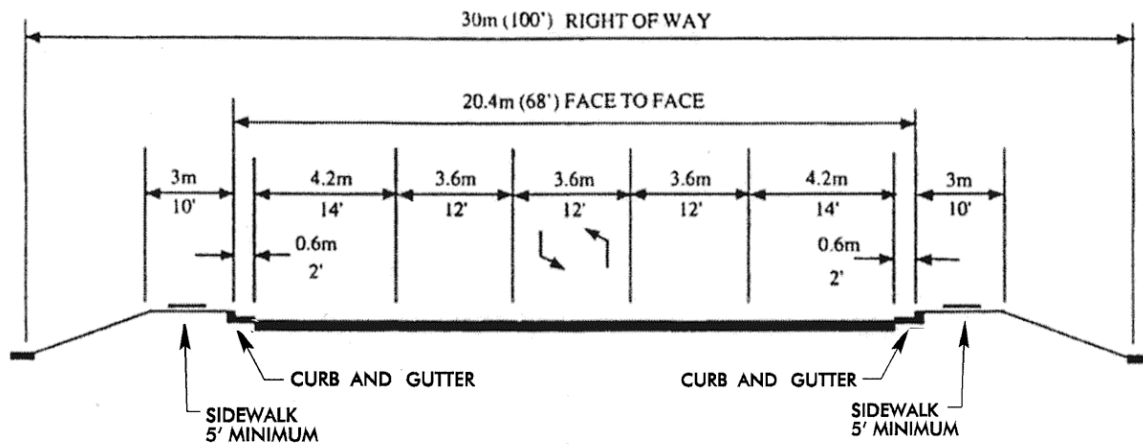

C-5

Typical Bicycle Cross Sections

B-3 BICYCLE LANES ON COLLECTOR STREETS

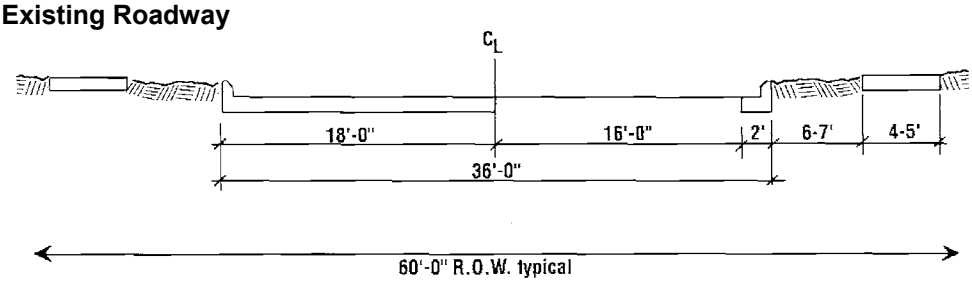

**Restriping to Accommodate
Bicycle Lanes (Does Not Allow
On-Street Parking)**

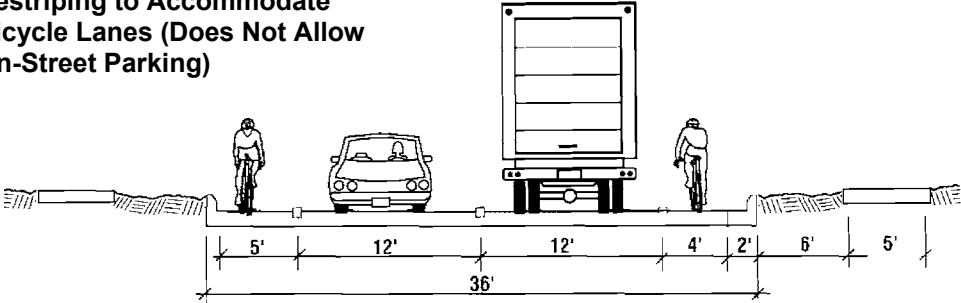

Typical Bicycle Cross Sections

B-4

WIDE PAVED SHOULDERS

Existing Roadway

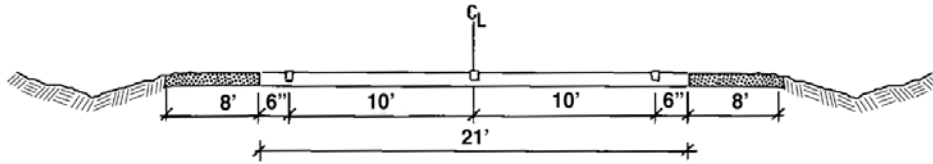

**Roadway Retrofitted with
4-Ft Paved Shoulders**

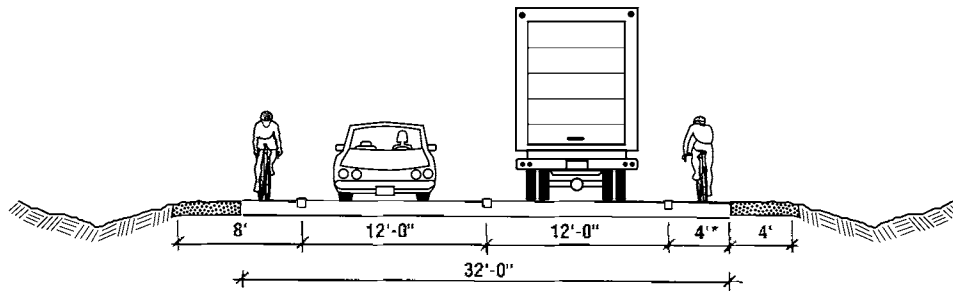

* If speeds are higher than 40 mph,
shoulder widths greater than 4' are
recommended.

C-7

Typical Bicycle Cross Sections

B-5 RECOMMENDED TYPICAL SECTION OF 10-FT ASPHALT PATHWAY With 2-Ft Select Material Shoulder

